

WINGMAN

HANGAR AIRCRAFT WASH SYSTEM

Electric Hot Water Foam and Rinse System
Designed for In-Hangar
Washing of Fixed Wing
and Rotary Aircraft



WASH AND RINSE WITH AIRCRAFT-SAFE WATER PRESSURE

Conducting wash operations in the refuge of a hangar offers protection from water evaporation, and premature soap dehydration caused by wind and varying temperature. While most hangars are equipped with drains for washing indoors, very few are equipped with a wash system that complies with TM 1-1500-344-23-2, TO 1-1-691, NAVAIR 01-1A-509-1 guidelines for aircraft safe washing.

Technical manuals are very specific relative to the damage caused by washing with a standard, high pressure system that can drive water into mechanical struts, avionics panels and air frame seams resulting in long-term, irreversible damage. The aircraft-safe water pressure Wingman provides the optimal solution.



Adheres to:
T.O. 1-1-691, Aircraft Weapon Systems
Cleaning and Corrosion Control
(NAVAIR 01-1A-509, TM 1-1500-344-23-2)



 **GripStart™**

RIVEER™

The Solution is Clear with Riveer™

WINGMAN

Hangar Aircraft Wash System

Historically, modifying a hangar to implement or replace wash systems can involve many different authorities, delaying readiness beyond acceptability. While many shortcuts involve towing diesel powered wash systems into the hangar for intermittent use, safety and health concerns limit this as a long term solution. The growing concern regarding enclosed space operation of diesel fired units combined with the need for readiness NOW has driven the development of the Wingman, a total electric system enabling plug and play capability utilizing MIL Spec connections for water and electricity commonly found in hangars for use with existing ground support equipment.

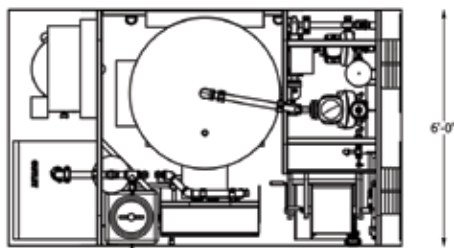

WINGMAN SPECIFICATIONS

Part Number: HWHW-10F
Length: 10' 0"
Width: 6' 0"
Height: 9' 0"
Dry weight: 2,900lbs
Cage: 5X781

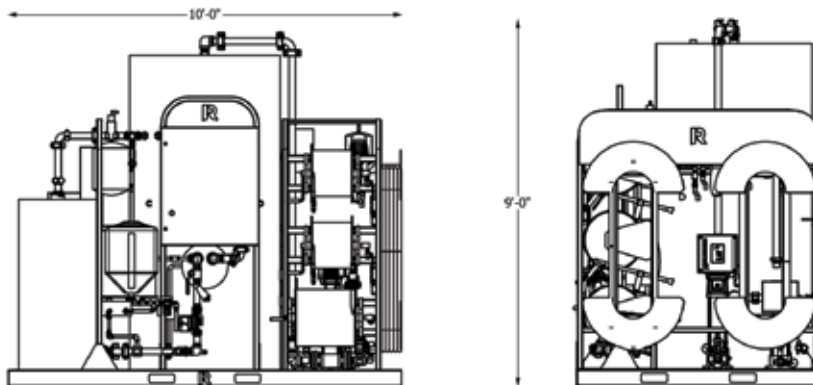

FEATURES

- 2 Rinse Guns- 10 GPM flow rate each with variable spray pattern control
- 1 Foamer gun- 50 GPM
- Configurable operating pressure to meet airframe specific guidelines
- 30-80 PSI (Boeing) configuration, or 175 PSI
- 500 gallons of hot water @ 140°F
- Variable frequency drive pumps (VFD) with stainless steel pump heads
- Powder coated skid
- Insulated hot water tank
- Water connection: 3/4" garden hose fitting and 2" NST hydrant connection
- Electric connection: X1806-71 Crouse Hinds plug
- Powder coated hose reels
- Run dry protection
- Total electric, zero emission
- Ultra-high efficiency boiler section exceeds DoD building standards for 95% efficiency
- No exhaust stack required, no venting required.
- Reach up to 50' from ground, less need for lifts or ladders

BUILT TO STANDARDS

- **NEC 2017/NFPA30:** National Electric Code as adopted in 2017.
- **MIL-STD-461:** Requirements for the Control of Electromagnetic Interference Characteristics of Subsystems and Equipment
- **MIL-STD-209K:** Interface Standard for Lifting and Tie down Provisions
- **MIL-STD-810G:** Environmental Engineering Considerations and Laboratory Tests
- **UL 508A:** Standard for Industrial Control Panels
- **NFPA 70:** National Electric Code

